



US006936300B2

(12) **United States Patent**  
**Lee et al.**

(10) **Patent No.:** **US 6,936,300 B2**  
(45) **Date of Patent:** **Aug. 30, 2005**

(54) **METHOD FOR FABRICATING ORGANIC ELECTROLUMINESCENT DISPLAY**

(75) Inventors: **Seong Taek Lee**, Suwon (KR); **Jang Hyuk Kwon**, Suwon (KR); **Tae Min Kang**, Suwon (KR); **Joon Young Park**, Seoul (KR)

(73) Assignee: **Samsung SDI Co., Ltd.**, Suwon-si (KR)

(\*) Notice: Subject to any disclaimer, the term of this patent is extended or adjusted under 35 U.S.C. 154(b) by 368 days.

(21) Appl. No.: **09/935,332**

(22) Filed: **Aug. 23, 2001**

(65) **Prior Publication Data**

US 2002/0028626 A1 Mar. 7, 2002

(30) **Foreign Application Priority Data**

Aug. 24, 2000 (KR) ..... 2000-49287

(51) **Int. Cl.**<sup>7</sup> ..... **B05D 5/06**; B05D 5/12

(52) **U.S. Cl.** ..... **427/66**; 427/68; 427/555; 427/596

(58) **Field of Search** ..... 427/66, 68, 555, 427/596

(56) **References Cited**

**U.S. PATENT DOCUMENTS**

4,819,033 A \* 4/1989 Yoshitake et al. .... 355/53

5,290,280 A \* 3/1994 Daikuzono ..... 606/16  
5,688,551 A \* 11/1997 Littman et al. .... 427/64  
5,990,924 A \* 11/1999 Kido et al. .... 347/254  
6,114,088 A \* 9/2000 Wolk et al. .... 430/273.1  
6,137,631 A \* 10/2000 Moulin ..... 359/618  
6,242,140 B1 \* 6/2001 Kwon et al. .... 430/7  
6,358,664 B1 \* 3/2002 Nirmal et al. .... 430/200

\* cited by examiner

*Primary Examiner*—Michael Cleveland

(74) *Attorney, Agent, or Firm*—Stein, McEwen & Bui, LLP

(57) **ABSTRACT**

Relating to a method for fabricating an organic electroluminescent display having improved surface flatness and thickness uniformity as well as an improved image quality at edge regions of a pattern, a method for fabricating an organic electroluminescent display includes the steps of: forming a first electrode layer on a transparent substrate, the first electrode layer being a positive electrode; forming an assistant layer on the first electrode layer; forming an organic luminescent layer on the assistant layer by scanning a donor film using a laser beam, the donor film being disposed on the substrate having luminescent materials for R, G, and B; removing the donor film; and forming a second electrode layer on the organic luminescent layer, the second electrode layer being a negative electrode, wherein the step of forming an organic luminescent layer comprises the step of dithering the laser beam in a direction perpendicular to a scanning direction of the laser beam.

**3 Claims, 8 Drawing Sheets**

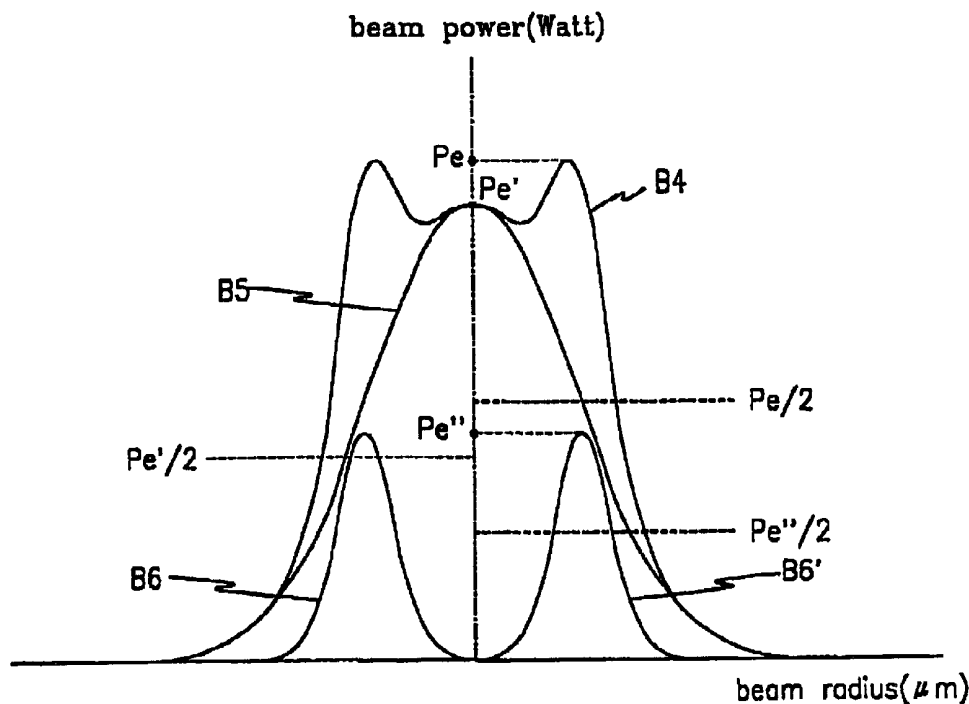

【fig. 1】

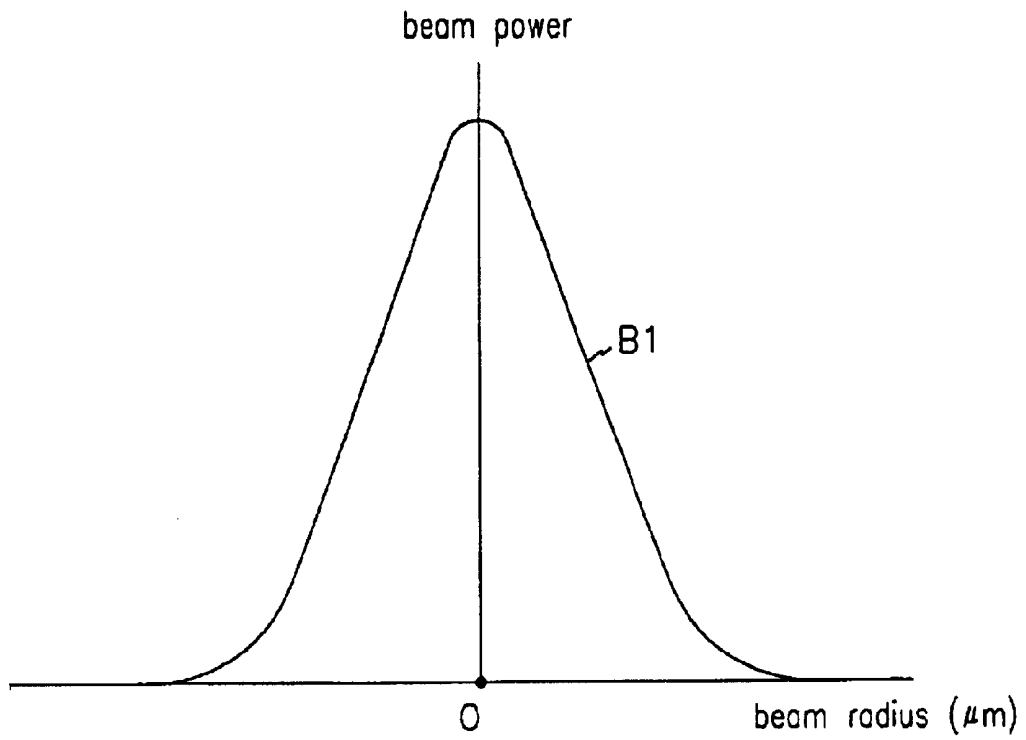

【fig. 2】

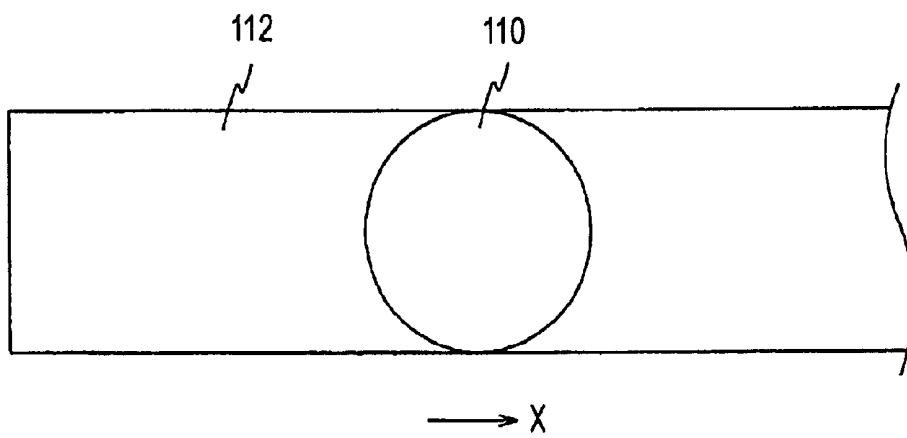

FIG. 3

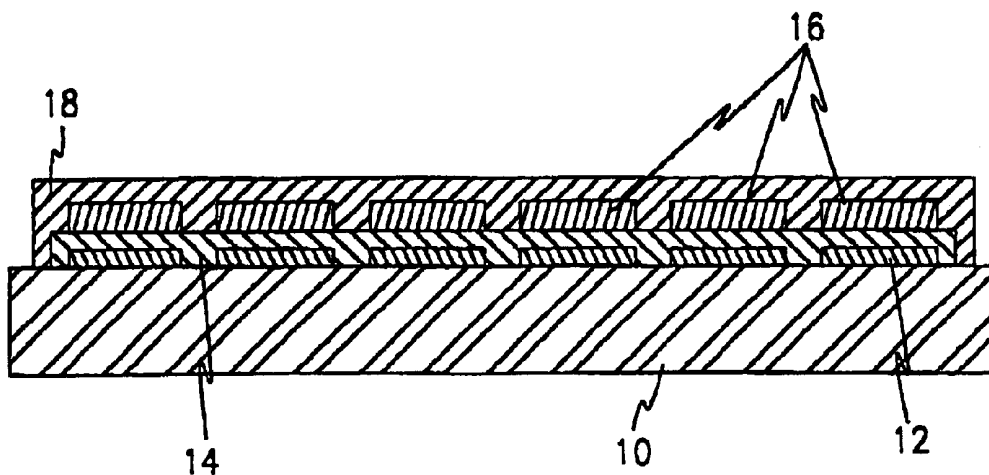

FIG. 4

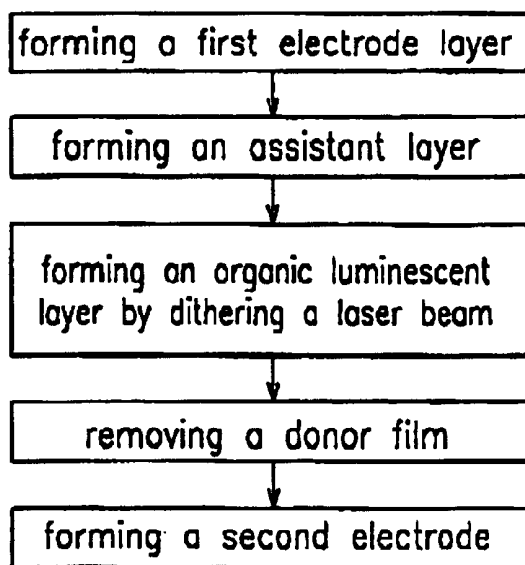

FIG. 5

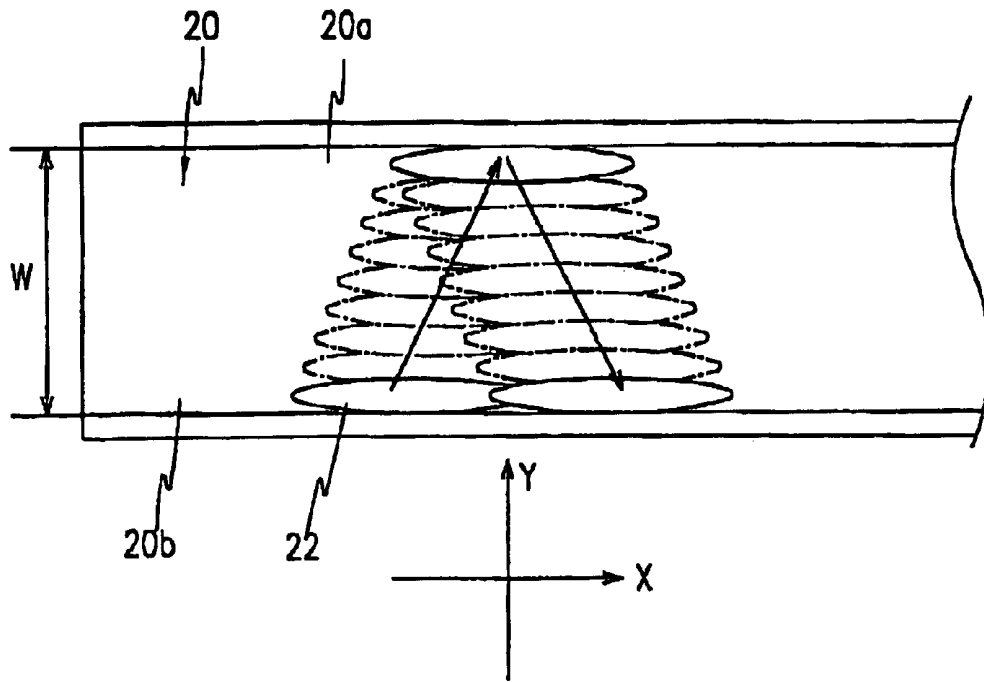

FIG. 6

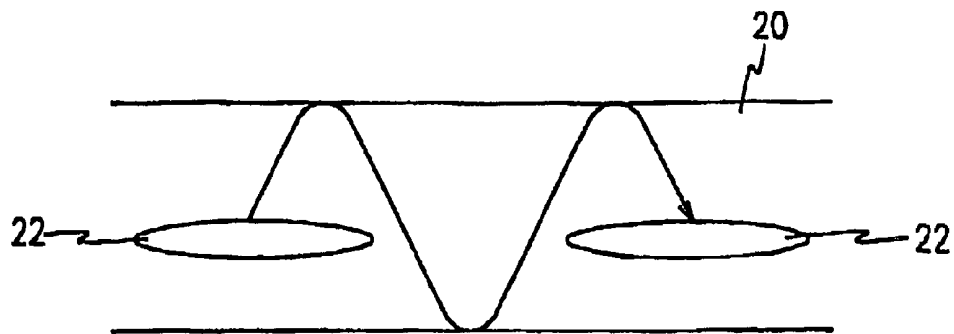

FIG. 7

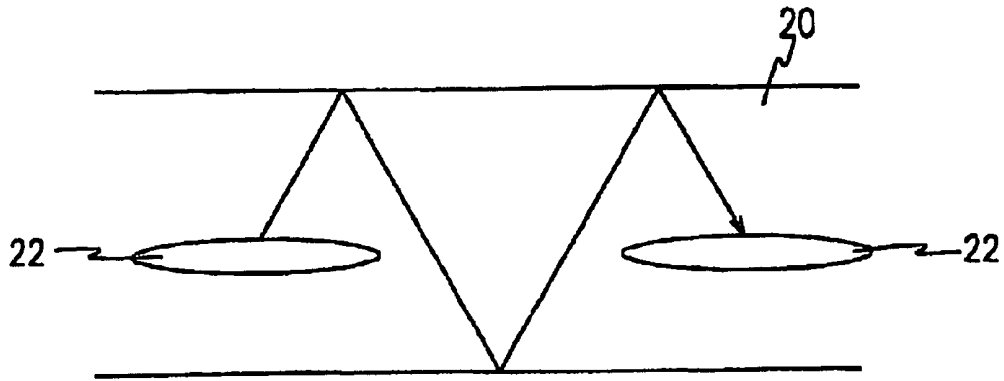

FIG. 8

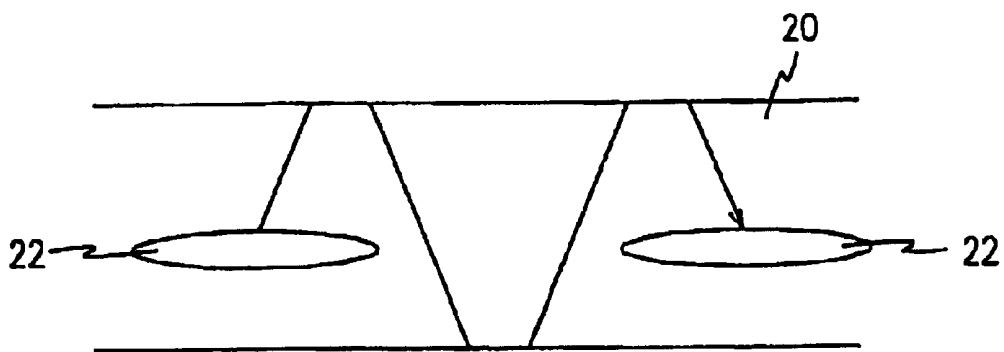

FIG. 9

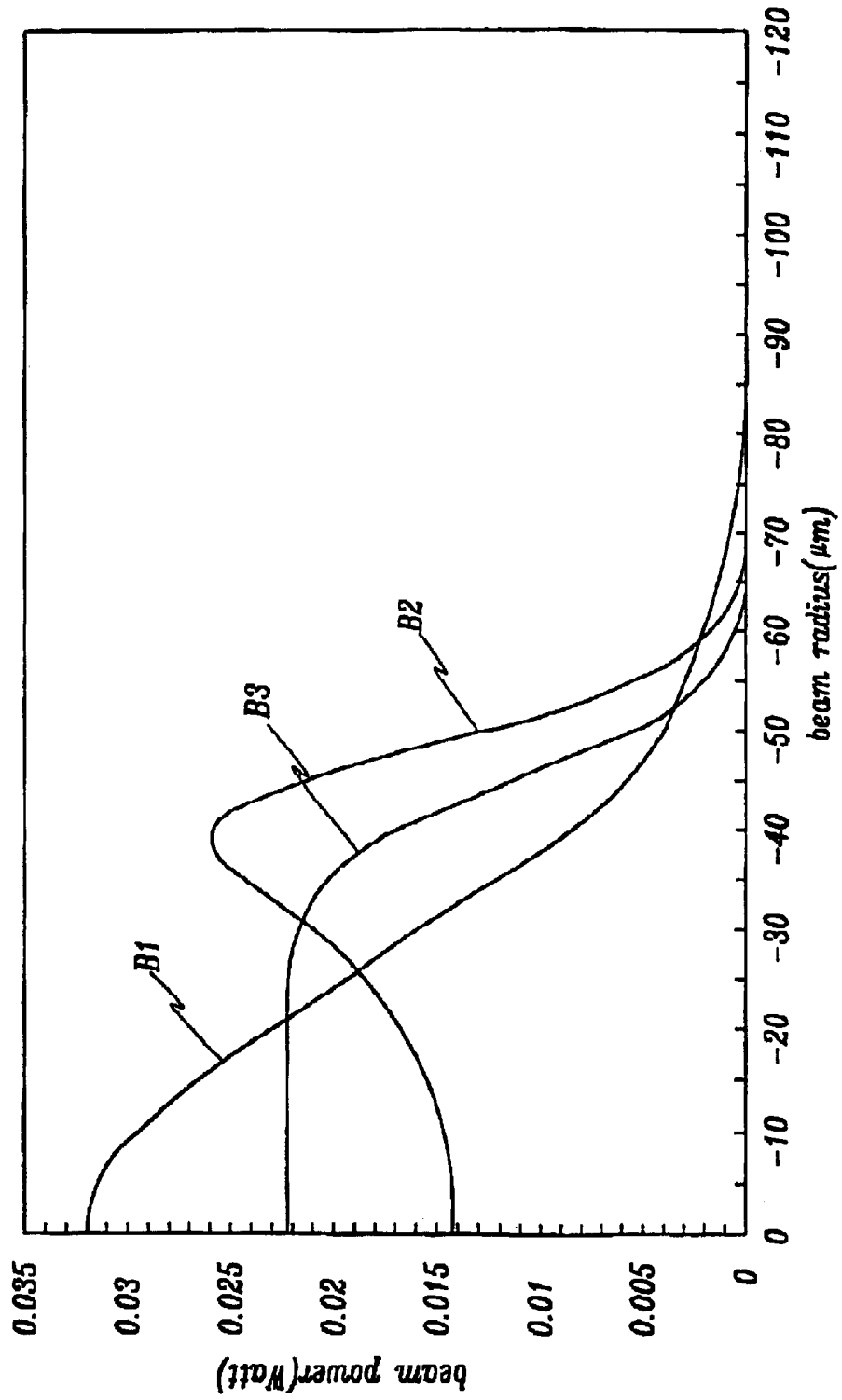

FIG.10

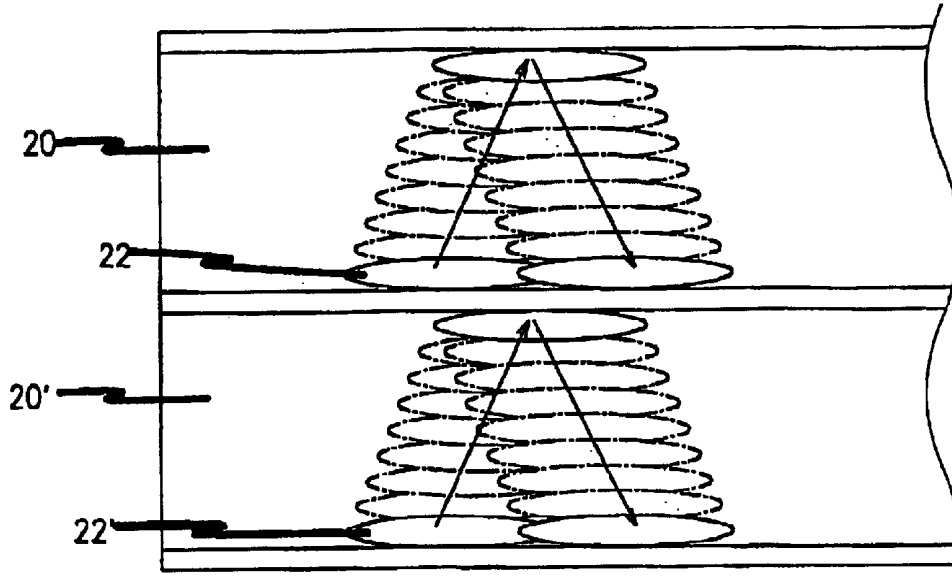

FIG.11

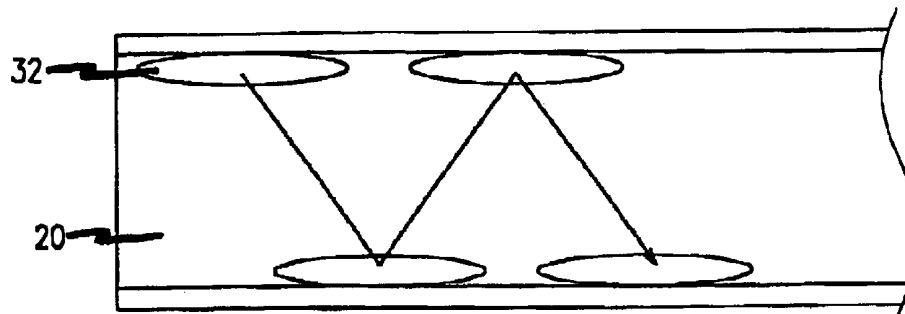

FIG.12

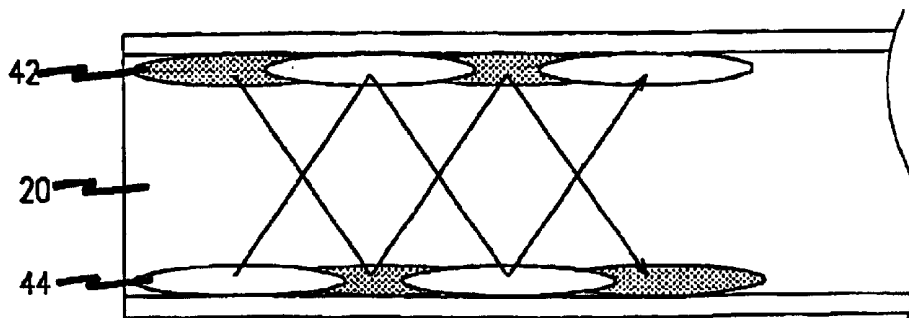

FIG.13

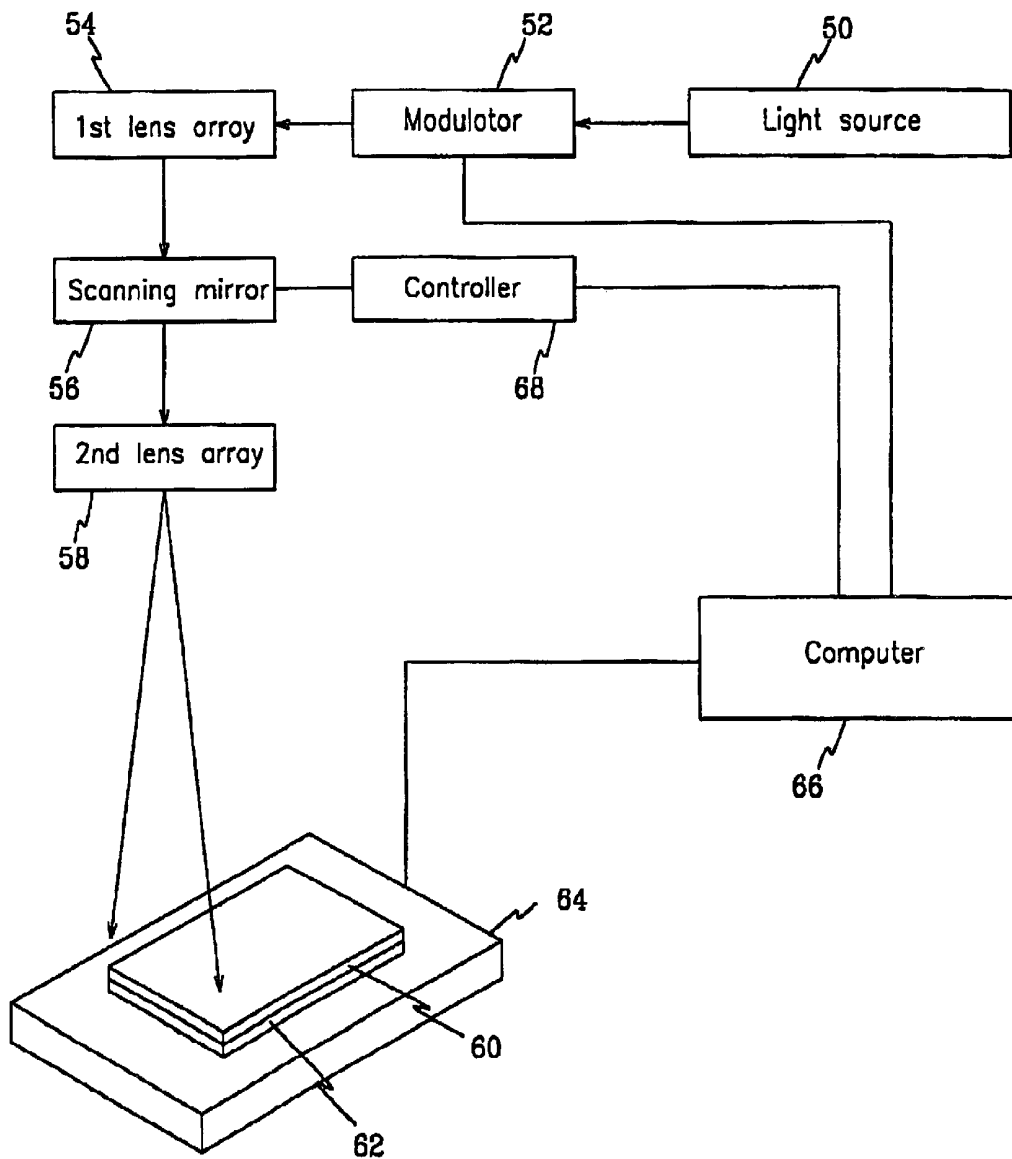

FIG.14

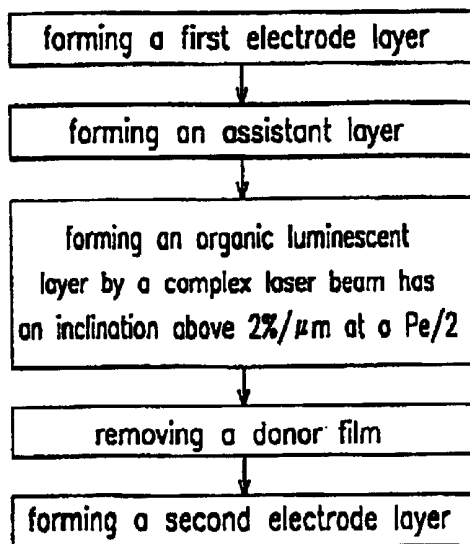
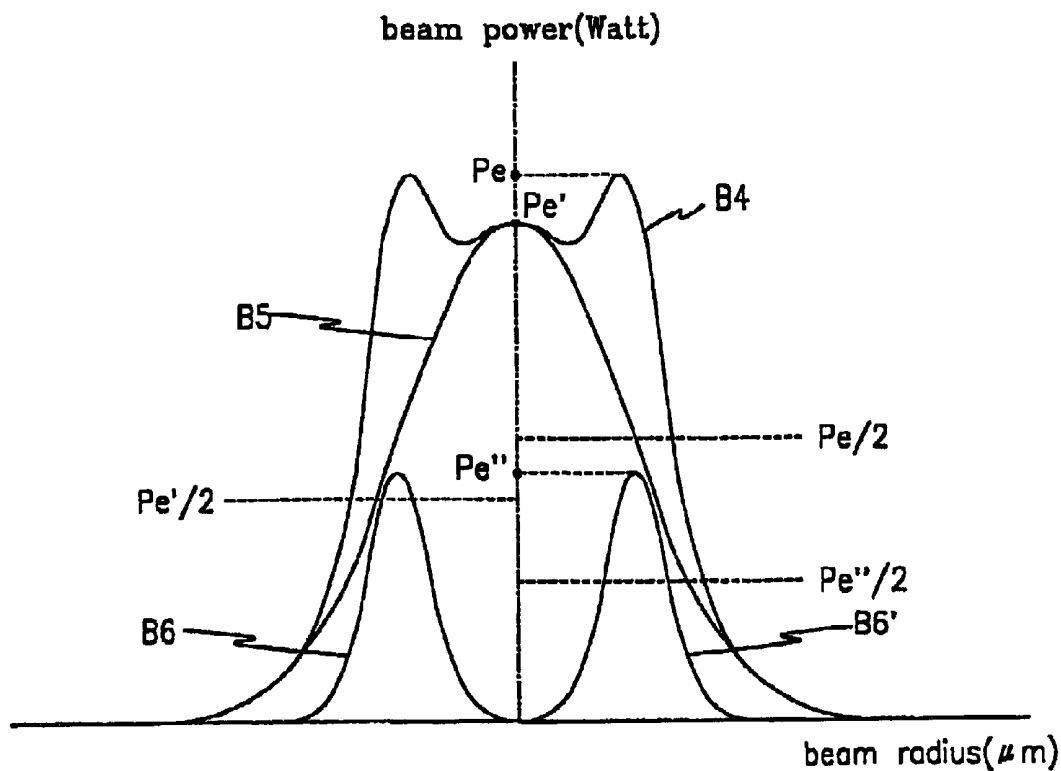

FIG.15



## METHOD FOR FABRICATING ORGANIC ELECTROLUMINESCENT DISPLAY

### OBJECT OF THE INVENTION

[Field of the Invention and Description of the Related Art]

The present invention relates to a method for fabricating an organic electroluminescent display, and more particularly, to a method for fabricating an organic electroluminescent display having improved surface flatness and thickness uniformity as well as an improved image quality at edge regions of a pattern.

An electroluminescent display includes an electroluminescent material disposed between electrodes, and is designed to realize an image by applying a voltage to the electrodes so as to form an electric field therebetween such that the electroluminescent material may become luminescent. Such an electroluminescent display is classified into an inorganic electroluminescent display and an organic electroluminescent display depending on the electroluminescent material. The inorganic electroluminescent display has been put into practical use and is widely used for a backlight of a watch, and the organic electroluminescent display is under strong investigation since it shows merits of high luminance and efficiency, drivability by a low voltage, and high responsiveness, in comparison with the inorganic one.

Generally, such an organic electroluminescent display includes a transparent substrate, on which an anode electrode, an organic luminescent layer, and a cathode electrode are consecutively disposed.

The organic luminescent layer may have a variety of structures depending on an electroluminescent material. For example, the organic luminescent layer may be formed of a hole transport layer, an luminescent layer, and an electron transport layer, or of a hole transport layer and an electron transport/luminescent layer, or of a hole transport/luminescent layer.

In the above described organic electroluminescent display, the organic luminescent layer is designed to realize red (R), green (G), and blue (B) colors so that it can be applied to a color display.

Such an organic luminescent layer is generally formed through a vacuum evaporative deposition process using a shadow mask or through a conventional optical etching process. However, the vacuum evaporative deposition process has a limitation in reducing the physical gap between the patterns and it is difficult to form a minute pattern to tens of  $\mu\text{m}$  level which is required against the possible deformation of the mask. When the optical etching process is applied, although it is possible to form the minute pattern, practical application becomes difficult since the property of the luminescent material forming the organic luminescent layer may be deteriorated by the developing solution or the etching solution.

Therefore, a thermal transferring method that is a kind of dry etching processes has been recently proposed to form the organic luminescent layer.

The thermal transferring method converts light emitted from a light source into thermal energy by which an image formation material is transferred to a substrate to form a color pattern. Therefore, to perform the thermal transferring method, a light source, a donor film and a substrate are required.

That is, as for a brief description of formation of a color image according to thermal transferring method, a light

emitted from a light source such as a laser is scanned on a donor film to be absorbed by absorbent of the donor film such that the light becomes converted to thermal energy, and color material of the donor film is transferred to a surface thereof by the thermal energy.

Actually, according to the thermal transferring method, a color image is formed by scanning a laser beam of a desirably adjusted focus to the donor film disposed on the substrate according to a desired pattern.

For an example of such a prior art, U.S. Pat. No. 5,521,035 discloses a method for fabricating a color filter for a liquid crystal display through a laser thermal transferring process.

In this patent, the color filter is fabricated by a laser induction thermal transferring process for transferring a color material from a donor film to a substrate such as a glass or a polymeric film. As a laser unit, an Nd:YAG laser system is used for transferring the color material to the surface of the substrate.

The Nd:YAG laser forms a Gaussian beam having a distribution of a Gaussian function shape. When a diameter of the Gaussian beam is set large (approximately, above 60  $\mu\text{m}$ ), the inclination of the energy distribution is slowly reduced as it goes away from the center point.

Therefore, as shown in FIG. 2, when the Gaussian beam **110** having a predetermined diameter is scanned in an X-direction as shown in FIG. 2, since the beam intensity is low at the both edges of a color pattern **112**, the quality of the color pattern **112** at the both edges is deteriorated when compared with the central portion.

[Object to be achieved by the present invention]

When the energy of the laser beam is intensified to improve the image quality at the edges in order to solve the above problem, although the image quality at the edges may be enhanced, the surface of the image pattern becomes irregular since the energy is excessively increased at the central portion.

At this point, the present invention has been made to solve the problem, and an objective of the present invention is to provide a method for fabricating an organic electroluminescent display having an improved surface flatness and thickness uniformity as well as an improved image quality at edge regions of a pattern

[Constitution and Operation of the Invention]

In order to achieve the objective, the present invention provides a method for fabricating an organic electroluminescent display wherein a laser beam is dithered in a direction perpendicular to a scanning direction of the laser beam while forming an organic luminescent layer on the assistant layer by scanning a donor film using a laser beam, the donor film being disposed on the substrate having luminescent materials for R, G, and B.

In addition, the present invention provides a method for fabricating an organic electroluminescent display wherein a single laser beam formed by a composition of a laser beam having gentle inclination in energy distribution and a laser beam having steep inclination in energy distribution such that inclination in energy distribution is increased at a threshold energy is utilized while forming an organic luminescent layer on the assistant layer by scanning a donor film using a laser beam, the donor film being disposed on the substrate having luminescent materials for R, G, and B.

Thereby, thermal transferring at a pattern edge of an organic luminescent layer is ensured.

Preferred embodiments of the present invention will be described in detail with reference to the accompanying drawings.

## BRIEF DESCRIPTION OF THE DRAWINGS

FIG. 1 is a graph for illustrating an energy distribution of a laser beam used for a conventional thermal transferring method.

FIG. 2 is a schematic view for illustrating a method for forming a pattern using a conventional thermal transferring method.

FIG. 3 is a block diagram for illustrating a method for fabricating an organic electroluminescent display.

FIG. 4 is a schematic view of an organic electroluminescent display fabricated according to a method shown in FIG. 3.

FIG. 5 is a schematic view for illustrating a method for fabricating an organic electroluminescent display according to a first embodiment of the present invention.

FIGS. 6 to 8 are schematic views for illustrating dithering examples of a laser beam used for the present invention.

FIG. 9 is a graph for illustrating a sectional energy distribution of a laser beam used for the present invention.

FIG. 10 is a schematic view for illustrating a method for fabricating an organic electroluminescent display according to a second embodiment of the present invention.

FIG. 11 is a schematic view for illustrating a method for fabricating an organic electroluminescent display according to a third embodiment of the present invention.

FIG. 12 is a schematic view for illustrating a method for fabricating an organic electroluminescent display according to a fourth embodiment of the present invention.

FIG. 13 is a schematic view for illustrating a transferring apparatus used for the present invention.

FIG. 14 is a block diagram for illustrating a method for fabricating an organic electroluminescent display according to another embodiment of the present invention.

FIG. 15 is a graph for illustrating a sectional energy distribution of a laser beam applied to another embodiment of the present invention.

## DETAILED DESCRIPTION OF THE INVENTION

FIG. 3 is a block diagram for illustrating a method for fabricating an organic electroluminescent display, and FIG. 4 is a schematic view of an organic electroluminescent display fabricated according to a method shown in FIG. 3.

As shown in the drawings, first electrode layers 12 having a thickness of about 100–500 nm is formed on a transparent substrate 10 by sputtering indium tin oxide (ITO).

An assistant layer (hole transport layer) 14 having a thickness of about 10–100 nm is formed on the first electrode layer 12 by, for example, a spin coating process, a dip coating process, a vacuum evaporative deposition process, or a thermal transferring process. An R-G-B organic luminescent layer 16 is formed on the assistant layer 14 by a thermal transferring process. A second electrode layer 18 intersecting the first electrode layer is formed on the organic luminescent layer 16.

Here, an insulating layer formed of an organic material such as polymer photoresist or an inorganic material such as SiO<sub>2</sub>, and SiN<sub>2</sub> may be deposited between the line patterns of the first electrode. The second electrode layer 18 may be formed by depositing aluminum through a vacuum evaporative deposition process at a thickness of about 50–1500 nm.

In addition, for an increase of an efficiency, a material such as LiF may be disposed between the organic luminescent layer and the second electrode layer.

In order for forming an organic luminescent layer by a thermal transferring method, a donor film formed of a base film, a light absorption layer, and a transfer layer is required, and a desired pattern of the emission layer is obtained by scanning a laser beam after disposing the donor film on an upper side of a substrate provided with the first electrode layer and the assistant layer.

In order for fabricate a full colored organic electroluminescent display, three donor films for the three colors of R, G, and B is required, and emission patterns of R, G, and B may be obtained by three times of scanning process on respective donor films.

Emission pattern of an organic electroluminescent display should show flatness on the surface, high image quality at the edges, and uniform thickness distribution. Therefore, in order for forming an organic emission layer by a thermal transferring method, it is preferable that energy distribution of a laser beam scanned on the donor film is uniform and shows rapid inclination near the edges such that width may not fluctuate due to non-uniform sensitivity of the donor film.

Therefore, it necessitates an alteration of laser beam from energy distribution of Gaussian shape such that energy is decreased in its central portion while energy distribution rapidly change near the edges. For such an alteration of an energy distribution, according to the present invention, the laser beam may be dithered in a perpendicular direction with respect to a scanning direction of the beam, or a single beam composed of a plurality of laser beams having different energy distribution. The scheme of dithering a laser beam is first described.

FIG. 5 is a schematic view for illustrating a method for fabricating an organic electroluminescent display according to a first embodiment of the present. In the drawing, the reference numeral 20 indicates a pattern of an organic luminescent layer to be formed on an assistant layer.

And, the reference numeral 22 indicates a laser beam as a light source for scanning the pattern 20.

The laser beam 22 moves in an X-direction shown in the drawing (i.e., from the left to the right in the drawing) along the pattern 20 to perform the scanning process. At this point, differently from the prior art, while moving in the X-direction, the laser beam 22 dithers in a Y-direction.

By the dithering movement of the laser beam 22, the thermal 10 transferring process is effectively realized even at both edges 20a and 20b of the pattern 20. The dithering movement is realized by alternating the advancing direction of the laser beam under the control of an acousto-optic modulator (AOM).

In addition, the dithering speed is preferably higher than the scanning speed. In more detail, considering the scanning speed and the energy distribution, it is preferable to set the dithering speed at about 100–10,000 KHz.

Although the section of the laser beam 22 may be formed in various shapes such as a circular or an oval shape, an oval shape is more preferable. Particularly, in the case that the pattern 20 of the organic luminescent layer is formed lengthily in a lengthwise direction as shown in the drawing, it is preferable that the section of the oval-shaped laser beam 22 is designed to have its major axis aligned in the scanning direction of the beam, since energy distribution applied to the pattern 20 may become uniform over entire portion thereof due to an increase of overlapping ratio of the beam during scanning.

When the lateral width W of the pattern 20 is 60–150 μm, it is preferable that the section of the laser beam is oval-

shaped having its major axis of 200–500  $\mu\text{m}$  and its minor axis of 15–50  $\mu\text{m}$ .

As shown in FIGS. 6 to 8, the laser beam performs its scanning operation along a waveform of a sine wave (see FIG. 6), a saw-tooth wave (see FIG. 7), or a trapezoidal wave (see FIG. 8). At this point, the sectional energy distributions of the laser beam 22 for the waveforms are as shown in FIG. 9.

As shown in FIG. 9, when the laser beam performs its scanning operation without the dithering movement, the laser beam (i.e., Gaussian beam B1) has an energy distribution having an inclination gently reduced as it goes from the central portion to the edges of the pattern.

However, the laser beam 22 of the present invention has an energy distribution having an inclination steeply increased as it goes from the central portion to the edges of the pattern (See graphs B2 and B3 in FIG. 9 which respectively represent the laser beams performing their dithering movements in the shape of the sine wave and the trapezoidal wave).

Based on such energy distributions, it is found that the intensity of the laser beam 22 of the present invention is not reduced even at the edges 20a and 20b of the pattern 20 thereby effectively realizing the thermal transferring process there.

In addition, the laser beam 22 according to the present invention has similar intensity at its central portion and its edge portion, and accordingly, surface roughness of the pattern 20 may be prevented.

That is, when the beam intensity is increased to compensate for the intensity of the beam edge as in the conventional laser beam B1, the surface of the pattern becomes uneven. However, the laser beam of the present invention has the beam intensity throughout its entire area, there is no need to increase the beam intensity to compensate for the beam edge. As a result, the flatness of the pattern can be improved.

In the above-described first embodiment, a single laser beam is radiated from a single laser unit. However, the present invention is not limited to this.

That is, the laser beam 22 may be formed in various manners to form organic luminescent layer by a thermal transferring method, and another embodiment for the various manners is as follows.

FIG. 10 is a drawing for illustrating a method for fabricating an organic electroluminescent display according to a second embodiment of the present invention. According to the present embodiment, That is, as shown in FIG. 10, plural split laser beams 22 and 22' may be radiated from a single laser unit (not shown) so that plural organic luminescent layer patterns 20 and 20' are simultaneously scanned while dithering the laser beams 22 and 22'.

Preferably, the plural split laser beams 22 and 22' are synchronized.

When the plural laser beams 22 and 22' are dithered and scanned synchronously, a plurality of organic luminescent layer patterns are simultaneously formed by one operation.

In addition, differently from the second embodiment, a plurality of laser beams may be used for forming an organic luminescent layer.

FIGS. 11 and 12 are drawings for illustrating such a scheme. Firstly in FIG. 11, plural laser beams radiated from plural laser units (not shown) are overlapped one another to form a single overlapped laser beam 32 (in this case, each laser beam has the same energy distribution), and they are dithered and scanned.

That is, according to a third embodiment of the present invention, for example, lasers from two laser units are overlapped to be unified and they are dithered while scanning. According to such a scheme, beam intensities are doubled relative to laser beam from a single laser unit, and accordingly, scanning speed may be increased.

Alternatively, as shown in FIG. 12, plural laser beams 42 and 44 may be radiated from plural laser units (not shown) so as to perform the scanning operation with different phases without overlapping.

At this time, the plural laser beams have equal energy distribution.

In addition, the plural laser beams may be applied to adjacent organic luminescent layer patterns as shown in FIG. 10 so as to fabricate organic luminescent display by dithering and scanning. The plural laser beams are preferably synchronized.

FIG. 13 shows a thermal transferring apparatus used for the present invention.

Referring to the drawing, a high energy laser beam is radiated from a light source, i.e., a laser unit 50. A high energy solid laser such as a Nd/YAG laser or a gas laser such as a CO<sub>2</sub> laser are used as the light source.

As described above, the radiated laser beam may be either of a single laser beam radiated from one or more lasers or split laser beams formed by a splitting of such a single laser beam with equal intensity by a splitter.

The single laser beam or the split laser beams is adjusted in its intensity by a modulator 52 and then reach a scanning mirror 56 via a first lens array 54.

The scanning mirror 56 guides the laser beam to a target position on the substrate in the X-direction.

The laser beam that has reached the scanning mirror 56 is emitted, through a second lens array 58, to the donor film 60 on which a luminescent material is deposited. Then, the luminescent material deposited on the donor film 60 is transferred to the substrate 62, only at a portion scanned by the laser beam.

The donor film 60 and the substrate 62 are supported on a stage 64 whose movement is controlled by a computer 66. The computer 66 also controls the scanning mirror 56 through a scanning mirror controller 68.

The dithering movement of the laser beam is controlled by the modulator 52 which is controlled by the computer 66.

In the above description, embodiments are described in connection with various types of dithering the laser beam. However, according to the present invention, an organic luminescent layer may be formed using a single laser beam composed of a plurality of laser beams of different energy distributions, as shown in FIGS. 14 and 15.

The single laser beam B4 is formed by a composition of a laser beam B5 having a large size (i.e., having gentle inclination in energy distribution) and laser beams B6 and B6' having a small size (i.e., having steep inclination in energy distribution).

The single laser beam B4 formed as such may have a steep inclination in energy distribution at a threshold energy, i.e., a minimally required energy for a transferring, and a resultant pattern may have enhanced flatness and edge characteristics.

forming an organic luminescent layer using a single laser beam mixed plural laser beams having a different inclination in energy distribution

In an embodiment of the present invention, it is preferable that a poly phenylene vinylene (PPV)-based material or a polyfluorene (PF)-based material is used for the organic luminescent layer.

While this invention has been described in connection with what is presently considered to be the most practical and preferred embodiments, the present invention is not limited thereto. Various variations may be realized within the appended claims, detailed description of the present invention, and the drawings, and consequently, such variations should be understood to be within the scope of the present invention.

[Effect of the Invention]

As can be seen from the above description of the constitution and operation of the present invention, according to a method for fabricating an organic electroluminescent display according to the present invention, a Gaussian beam is dithered during scanning or a single beam formed by composition of a plurality of beams having different energy distributions. Therefore, image formation may be enhanced at the edges of the organic electroluminescent display, and quality of a organic electroluminescent layer due to enhanced flatness of the pattern surface.

What is claimed is:

1. A method for fabricating an organic electroluminescent display, comprising:

forming a first electrode layer on a transparent substrate; forming an organic luminescent layer on the first electrode layer by scanning a donor film disposed on the substrate using a laser beam;

removing the donor film; and

forming a second electrode layer on the organic luminescent layer,

wherein the laser beam is a complex laser formed by mixing a plurality of lasers having different energy distributions.

2. The method of claim 1, wherein the organic luminescent layer is formed of a poly phenylene vinylene (PPV)-based material or poly fluorine (PF)-based material.

3. The method of claim 1, wherein the complex laser beam has a section formed in an oval-shape having a longitudinal diameter greater than a lateral diameter, the longitudinal diameter is formed in a scan direction.

\* \* \* \* \*

UNITED STATES PATENT AND TRADEMARK OFFICE  
**CERTIFICATE OF CORRECTION**

PATENT NO. : 6,936,300 B2  
APPLICATION NO. : 09/935332  
DATED : August 30, 2005  
INVENTOR(S) : Taek Lee et al.

Page 1 of 26

It is certified that error appears in the above-identified patent and that said Letters Patent is hereby corrected as shown below:

ON THE TITLE PAGE ITEM (57) PLEASE **DELETE** ABSTRACT AND **REPLACE** WITH THE ATTACHED ABSTRACT.

IN THE SPECIFICATION PLEASE **DELETE** COLUMNS 1 –THROUGH 7 LINES 1 THROUGH 24 AND **INSERT** THE ATTACHED AS FOLLOWS.

THE TITLE PAGE, SHOWING AN ILLUSTRATIVE FIGURE, SHOULD BE **DELETED** AND **SUBSTITUTE** THEREFOR THE ATTACHED TITLE PAGE.

**DELETE** DRAWING SHEETS 1-8, AND **SUBSTITUTE** THEREFOR THE DRAWING SHEETS CONSISTING OF FIGS 1-15 AS SHOWN ON THE ATTACHED PAGES.

Signed and Sealed this

Twenty-fourth Day of April, 2007

A handwritten signature in black ink on a light gray dotted background. The signature reads "Jon W. Dudas" in a cursive style.

JON W. DUDAS

*Director of the United States Patent and Trademark Office*

(12) **United States Patent**  
Lee et al.

(10) **Patent No.:** US 6,936,300 B2  
(45) **Date of Patent:** Aug. 30, 2005

(54) **METHOD FOR FABRICATING ORGANIC ELECTROLUMINESCENT DISPLAY**

(75) **Inventors:** Seong Taek Lee, Suwon (KR); Jang Hyuk Kwon, Suwon (KR); The Min Kung, Suwon (KR); Joon Young Park, Seoul (KR)

(73) **Assignee:** Samsung SDI Co., Ltd., Suwon-si (KR)

(\*) **Notice:** Subject to any disclaimer, the term of this patent is extended or adjusted under 35 U.S.C. 154(b) by 368 days.

(21) **Appl. No.:** 09/935,332

(22) **Filed:** Aug. 23, 2001

(65) **Prior Publication Data**

US 2002/0028626 A1 Mar. 7, 2002

(30) **Foreign Application Priority Data**

Aug. 24, 2000 (KR) ..... 2000-49287

(51) **Int. Cl.<sup>7</sup>** ..... B05D 5/06; B05D 5/12

(52) **U.S. Cl.** ..... 427/66; 427/68; 427/555; 427/596

(58) **Field of Search** ..... 427/66, 68, 555, 427/596

(56) **References Cited**

U.S. PATENT DOCUMENTS

4,819,033 A \* 4/1989 Yoshitake et al. .... 355/53

5,290,280 A \* 3/1994 Daikuzono ..... 606/16  
5,688,551 A \* 11/1997 Littman et al. .... 427/64  
5,990,924 A \* 11/1999 Kido et al. .... 347/254  
6,114,068 A \* 9/2000 Wolk et al. .... 430/273.1  
6,137,631 A \* 10/2000 Moulin ..... 359/618  
6,242,140 B1 \* 6/2001 Kwon et al. .... 430/7  
6,358,664 B1 \* 3/2002 Nirmal et al. .... 430/200

\* cited by examiner

*Primary Examiner*—Michael Cleveland

(74) *Attorney, Agent, or Firm*—Stein, McEwen & Hui, LLP

(57) **ABSTRACT**

Relating to a method for fabricating an organic electroluminescent display having improved surface flatness and thickness uniformity as well as an improved image quality at edge regions of a pattern, a method for fabricating an organic electroluminescent display includes the steps of: forming a first electrode layer on a transparent substrate, the first electrode layer being a positive electrode; forming an assistant layer on the first electrode layer; forming an organic luminescent layer on the assistant layer by scanning a donor film using a laser beam, the donor film being disposed on the substrate having luminescent materials for R, G, and B; removing the donor film; and forming a second electrode layer on the organic luminescent layer, the second electrode layer being a negative electrode, wherein the step of forming an organic luminescent layer comprises the step of dithering the laser beam in a direction perpendicular to a scanning direction of the laser beam.

3 Claims, 8 Drawing Sheets

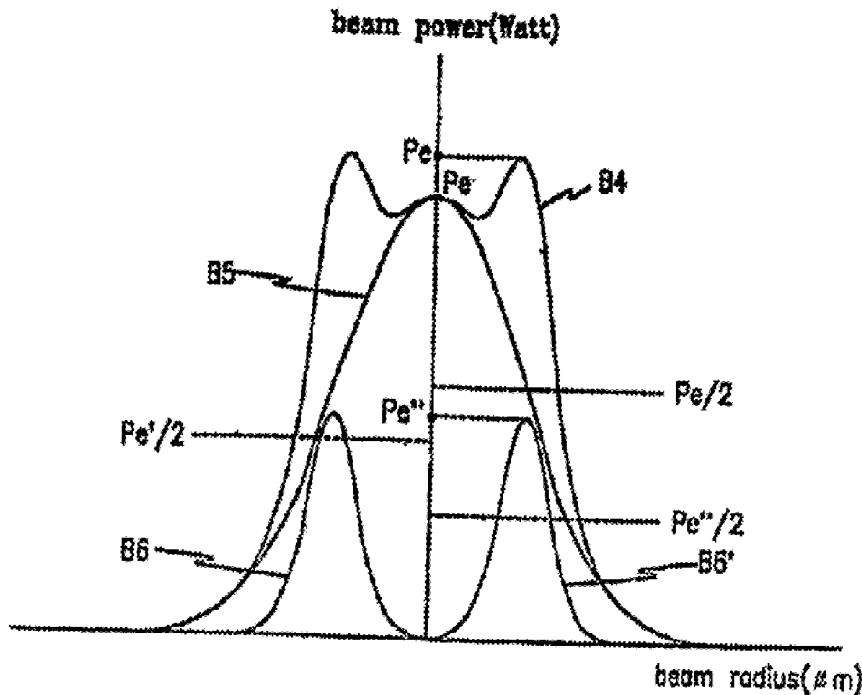

FIG.1  
(Conventional Art)

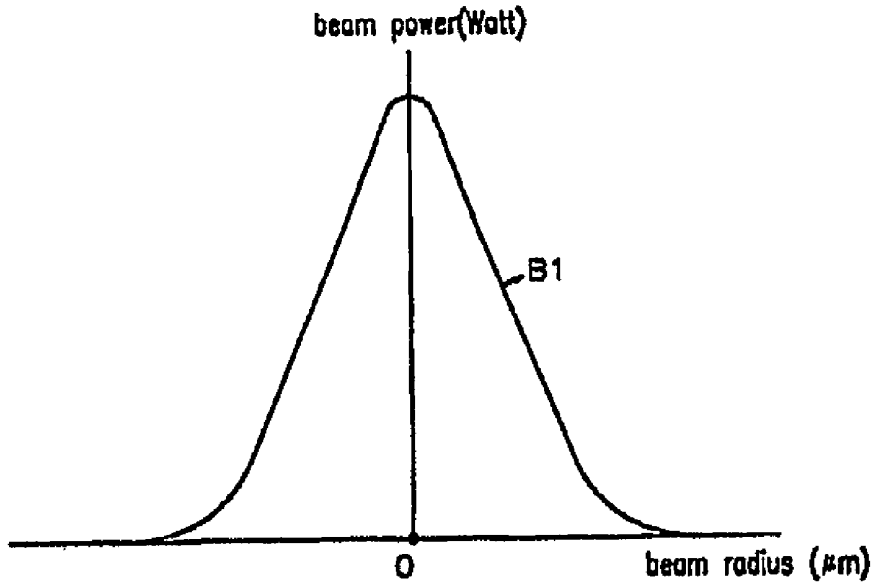

FIG.2  
(Conventional Art)

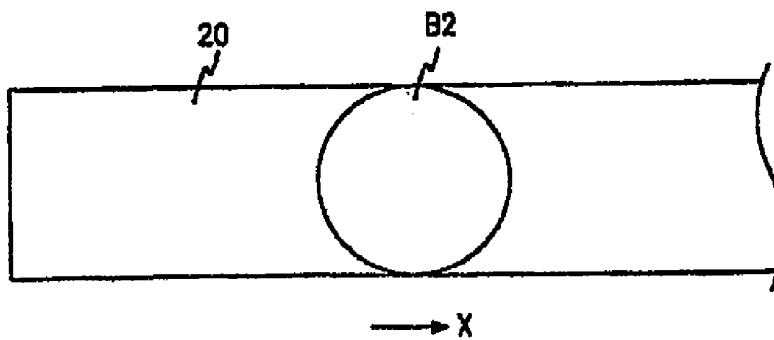

FIG. 3

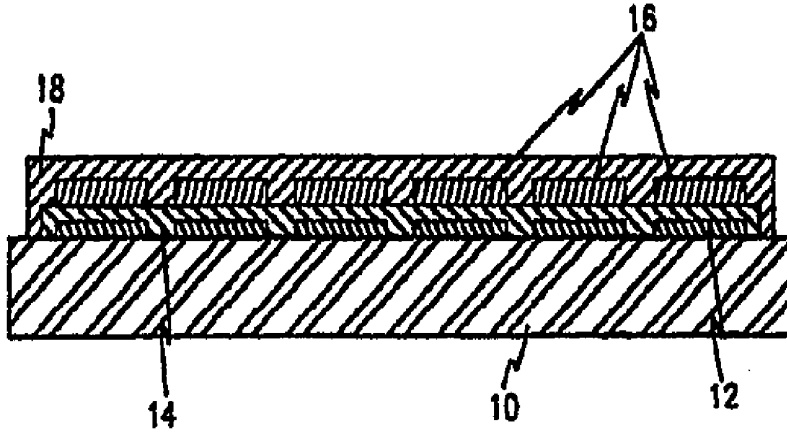

FIG. 4

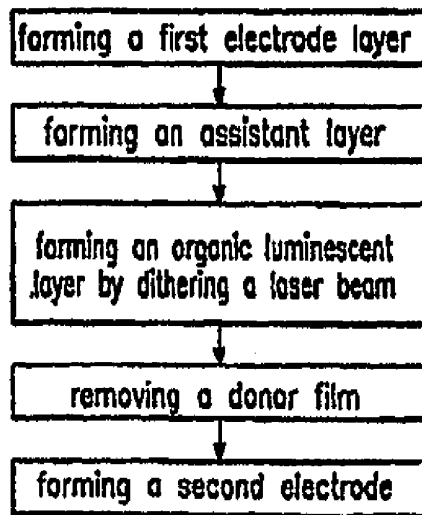

FIG. 5

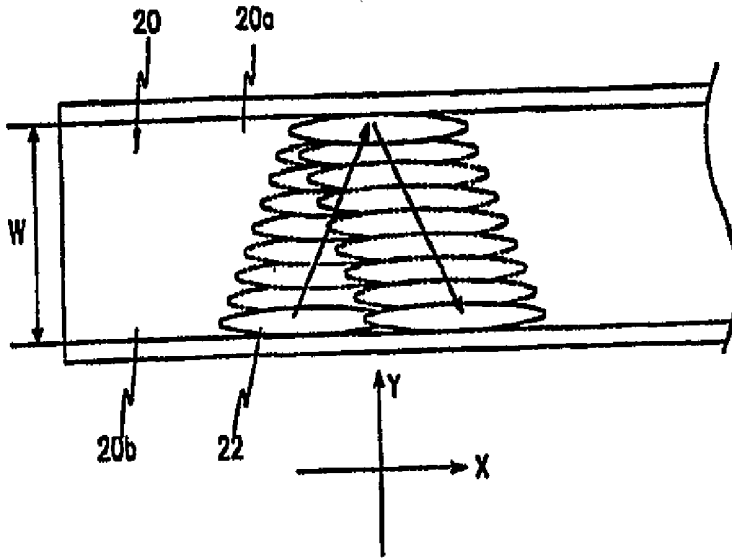

FIG. 6

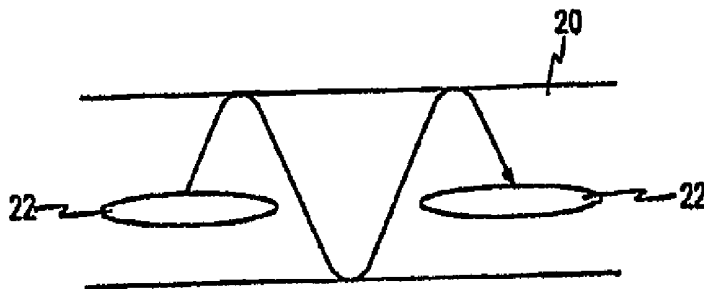

FIG. 7

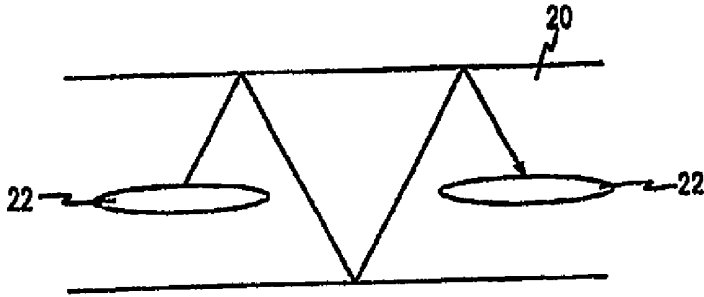

FIG. 8

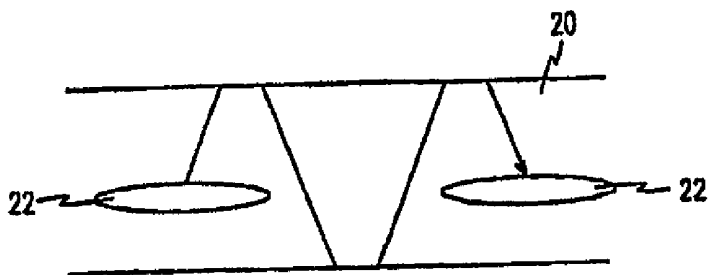

FIG. 9

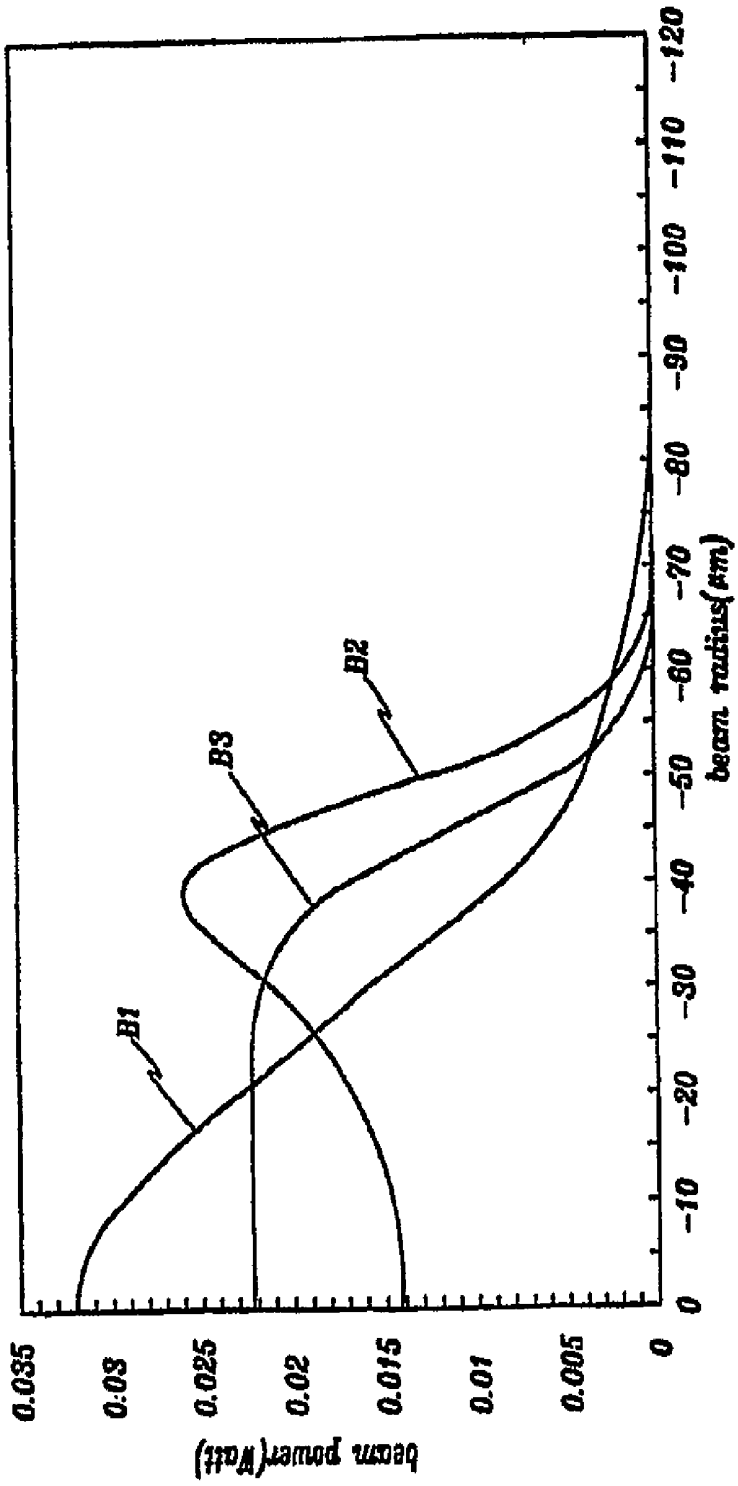

FIG.10

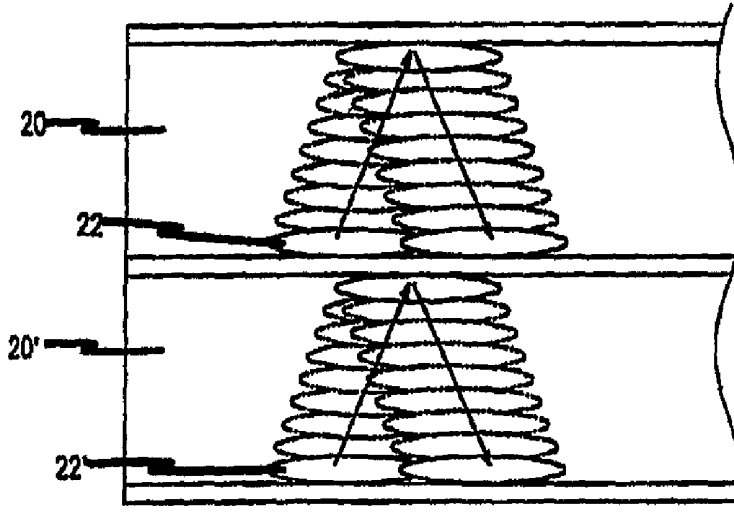

FIG.11

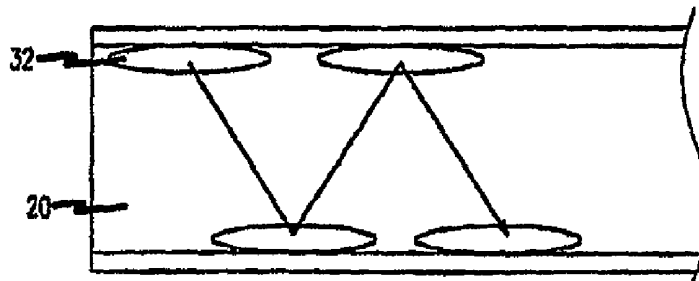

FIG.12

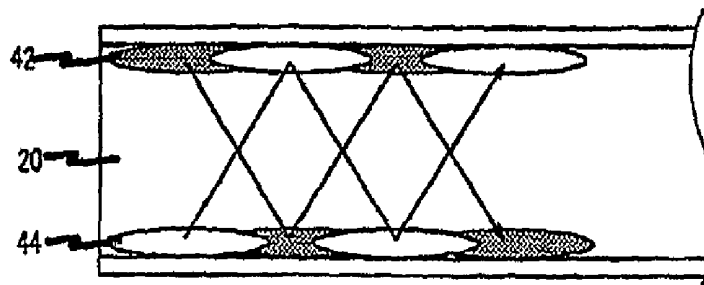

FIG.13

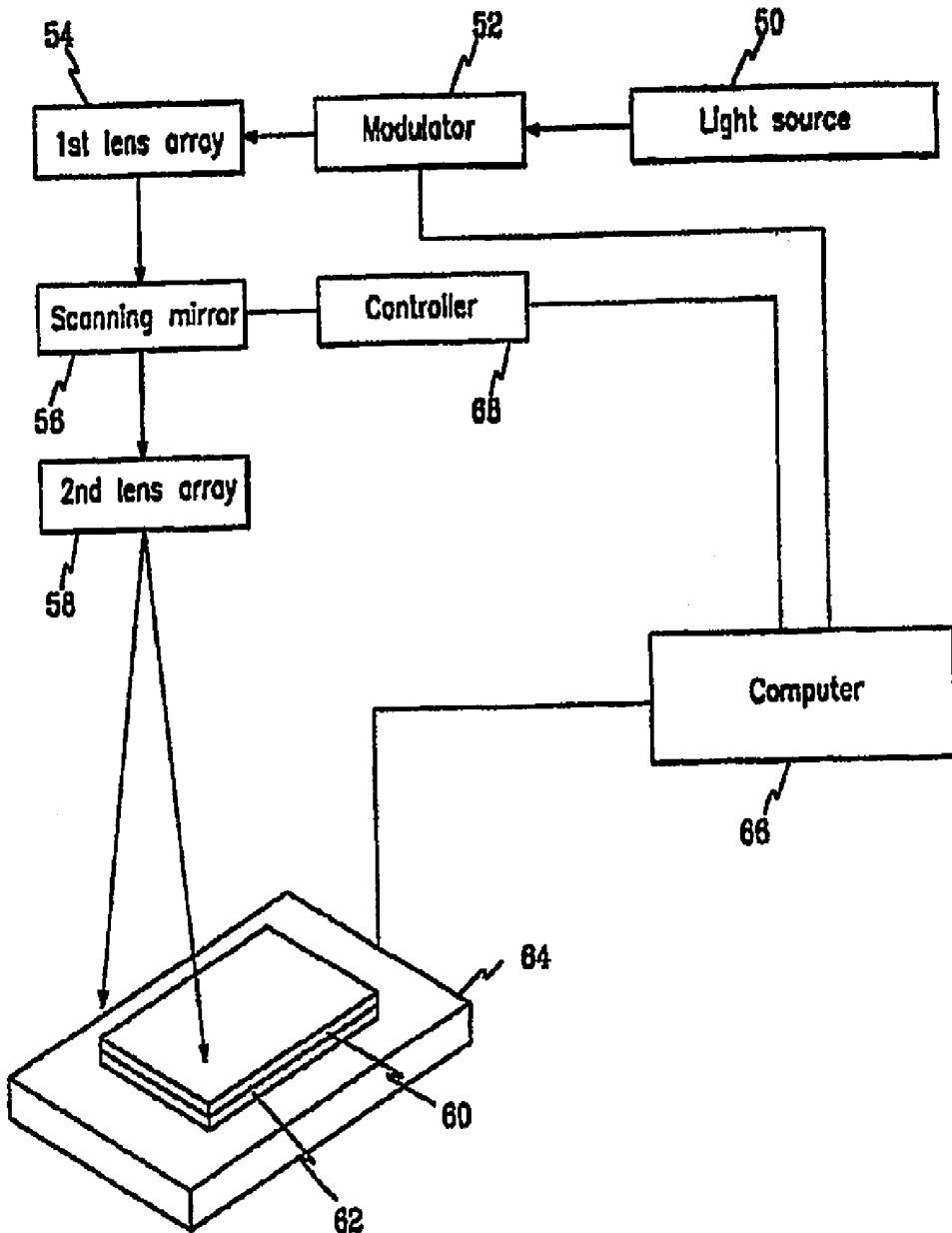

FIG.14

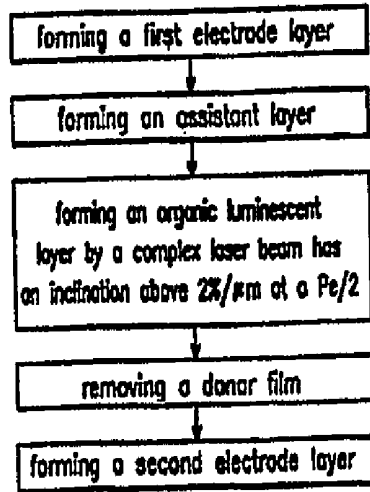
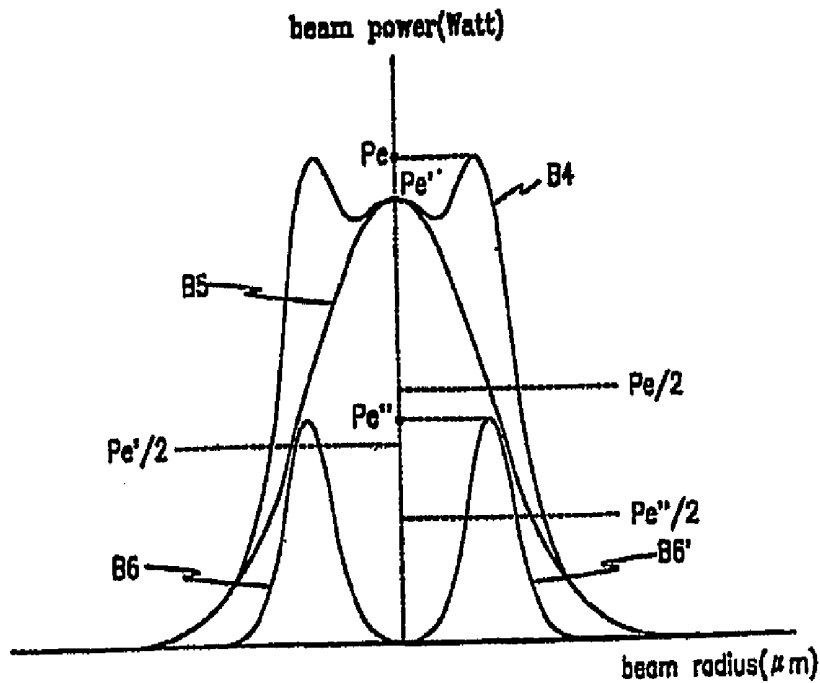

FIG.15



**ABSTRACT OF THE DISCLOSURE**

In a method for fabricating an organic electroluminescent display, a first electrode layer is formed on a transparent substrate, and a hole transport layer is formed on the first electrode layer. After an organic luminescent layer is formed on the hole transport layer by scanning a donor film disposed on the substrate using a laser beam, the donor film is removed and then a second electrode is formed on the organic luminescent layer. The laser beam dithers while performing the scanning operation to make the energy distribution uniform.

## **METHOD FOR FABRICATING ORGANIC ELECTROLUMINESCENT DISPLAY**

### **CROSSREFERENCE TO RELATED APPLICATION**

5           This application is based on application No. 2000-49287 filed with the Korea Patent Office on August 24, 2000, the content of which is incorporated herein by reference.

### **BACKGROUND OF THE INVENTION**

#### **10   1. Field of the Invention**

          The present invention relates to a method for fabricating an organic electroluminescent display that can improve the definition of an image at the edges of a pattern.

#### **2. Description of the Related Art**

15           An electroluminescent display is designed to realize an image by exciting an electroluminescent material disposed between electrodes by applying a voltage to the electrodes. Such an electroluminescent display is classified into an inorganic electroluminescent display and an organic electroluminescent display according to the electroluminescent material. The  
20   former is widely used for a backlight of a watch, while the latter is developed as a display as it advantages in that it can be driven with a low voltage and has a high responsiveness and polychrome.

          Generally, such an organic electroluminescent display comprises a transparent substrate, an anode electrode formed on the substrate, an organic

luminescent layer covering the anode electrode, and a cathode electrode formed on the organic luminescent layer.

The organic luminescent layer may have a variety of structures according to an electroluminescent material. For example, the organic luminescent layer may be formed of a hole transport layer, an luminescent layer, and an electron transport layer.

In the above described organic electroluminescent display, the organic luminescent layer is designed to realize red (R), green (G), and blue (B) colors so that it can be applied to a color display.

Such an organic luminescent layer is generally formed through a well-known vacuum evaporative deposition process or optical etching process. However, the vacuum evaporative deposition process has a limitation in reducing the physical gap between the patterns and it is difficult to form a minute pattern to tens of  $\mu\text{m}$  level which is required against the possible deformation of the mask. When the optical etching process is applied, although it is possible to form the minute pattern, the property of the luminescent material forming the organic luminescent layer may be deteriorated by the developing solution or the etching solution.

Therefore, in recent years, a thermal transferring method that is a kind of dry etching processes has been proposed to form the organic luminescent layer.

The thermal transferring method converts light emitted from a light source into thermal energy by which an image formation material is transferred to a substrate to form the organic luminescent layer. Therefore, to perform the

thermal transferring method, a light source, a donor film and a substrate are required.

Describing the thermal transferring method more in detail, when light is emitted from a light source such as a laser unit to a donor film, the light is converted into thermal energy by a light absorption material of the donor film. The thermal energy allows the luminescent material of the donor film to be transferred to the surface of the substrate to form the organic luminescent layer.

That is, the organic luminescent layer is formed by scan laser beam to the donor film disposed on the substrate. The focus of the laser beam is adjusted to a predetermined value, on the donor film disposed the substrate.

U.S. Patent No. 5,521,035 discloses a method for fabricating a color filter for a liquid crystal display through a laser thermal transferring process.

In the patent, the color filter is fabricated by a laser induction thermal transferring process for transferring a color material from a donor film to a substrate such as a glass or a polymeric film. As a laser unit, an Nd:YAG laser system may be used. This will be described with reference to FIG. 1.

As shown in FIG. 1, the Nd:YAG laser is designed to form a Gaussian beam B1 shaped in a Gaussian functional distribution. When a diameter of the Gaussian beam B1 is set above  $60\mu\text{m}$ , the inclination of the energy distribution is reduced as it goes away from the center point O.

Accordingly, as shown in FIG. 2, when the organic luminescent layer is formed by the scanning operation of the Gaussian beam B1 having a predetermined diameter in an X-direction, since the beam intensity is low at the both edges of the organic luminescent layer, the image quality at the both

edges 20 is deteriorated when compared with the central portion.

When the energy of the laser beam is intensified to improve the image quality at the edges 20, since the energy is excessively increased at the central portion, the surface of the image pattern becomes irregular.

5           When the laser thermal transferring method is used to form the color filter, a transfer material (color material) is formed of a binder polymer and pigment inducing color change and dispersed in the binder polymer (acrylic acid resin or epoxy resin) at a ratio of 20-40%. The binder polymer simply functions for transmitting light. Therefore, to form a desire color pattern, a kind of binder  
10 polymer, a Tg (Glass Transition Temperature) value or a molecular weight of the binder polymer should be properly modified.

Conventionally, the color material has a Tg value of about 60-120°C and a molecular weight of about 1,500-5,000. The color layer formed by the color material has a thickness of about 1-2 $\mu$ m.

15           When the laser thermal transferring method is used to form the organic electroluminescent display, the property (purity, Tg value, molecular weight and the like) of the transfer material (luminescent material) highly affects on the quality of the device. Therefore, when an inappropriate material is added, the quality of the device may suffer deathblow. Therefore, it is preferable to adjust  
20 the pattern quality by adjusting the laser transferring condition rather than modifying the property of the luminescent material.

Since the luminescent material used for the organic electroluminescent display has a molecular weight above 10,000 and a Tg value above 100°C, it is relatively difficult to perform the process for forming the organic luminescent

layer when compared with the process for forming the color layer. The thickness of the organic luminescent layer which should be realized through the laser thermal transferring method should be 50-100nm which is less than that of the color layer of the color filter.

5 Therefore, to form such a thin organic luminescent layer, scrupulous care in setting a laser beam transferring condition and an energy distribution is further required.

### **SUMMARY OF THE INVENTION**

10 It is an objective of the present invention to provide a method for fabricating an organic electroluminescent display having an improved pattern quality.

To achieve the above objective, the present invention provides a method for fabricating an organic electroluminescent display, comprising the  
15 steps of forming a first electrode layer on a transparent substrate; forming an assistant layer on the first electrode layer; forming an organic luminescent layer on the assistant layer by scanning a donor film disposed on the substrate, using a laser beam; removing the donor film; and forming a second electrode on the organic luminescent layer.

20 The step of forming an organic luminescent layer further comprises the step of allowing the laser beam to dither with respect to an advancing direction of the laser beam.

The laser beam is radiated from a single laser unit and splitted into more than two splitted laser beams, the splitted laser beams being synchronized to

simultaneously scan adjacent corresponding patterns.

Alternatively, the laser beam is formed of at least two laser beams which are radiated from at least two laser units and overlapped one another, the laser beams radiated from the laser units having an identical energy distribution.

6 Alternatively, the laser beam is formed of at least two laser beams radiated from at least two laser units and performing the scanning operation at a different phase. The laser beams are synchronized to simultaneously scan adjacent corresponding patterns.

10 A dithering speed of the laser beam is higher than an advancing speed of the laser beam.

Preferably, the dithering speed of the laser beam is about 100-1000kHz.

Preferably, the laser beam performs the dithering operation while making one of a frequency wave selected from the group consisting of a sine-wave, a sawtooth-wave, a trapezoid-wave, or a modified sine-wave.

15 The laser beam has a section formed in an oval-shape having a longitudinal diameter greater than a lateral diameter, the longitudinal diameter is formed in a scan direction.

Preferably, the longitudinal diameter is about 200-500 $\mu$ m and the lateral diameter is about 15-50 $\mu$ m.

20 Preferably, wherein the organic luminescent layer is formed of a poly phenylene vinylene (PPV)-based material or poly fluorine (PF)-based material.

According to another aspect, the laser beam is a complex laser beam formed by mixing a first laser beam having a smooth inclination at a  $P_e$  (peak of energy of the first laser beam)/2 and second laser beams having a steep

inclination at a  $P_e$  (peak of energy of the second laser beams)/2.

Preferably, the complex laser beam has an inclination above  $2\%/m$  at a  $P_e$  (peak of energy of the complex laser beam)/2.

Preferably, a section of the complex laser beam is formed in oval-  
5 shape.

Preferably, the complex laser beam has power of about 8W(Watt) and an advancing speed of about 5-11m/sec.

### BRIEF DESCRIPTION OF THE DRAWINGS

10 The accompanying drawings, which are incorporated in and constitute a part of the specification, illustrate an embodiment of the invention, and, together with the description, serve to explain the principles of the invention:

FIG. 1 is a graph for illustrating an energy distribution of a laser beam used for a conventional thermal transferring method;

16 FIG. 2 is a schematic view for illustrating a method for forming a pattern using a conventional thermal transferring method;

FIG. 3 is a schematic view for illustrating an organic electroluminescent display fabricated under the present invention;

FIG. 4 is a block diagram for illustrating a method for fabricating an  
20 organic electroluminescent display according to a first embodiment of the present invention;

FIG. 5 is a schematic view for illustrating a laser thermal transferring method described with reference to FIG. 4;

FIGS. 6 to 8 are schematic views for illustrating dithering examples of a

laser beam depicted in FIG. 5;

FIG. 9 is a graph for illustrating a sectional energy distribution of a laser beam used for a thermal transferring method that can be employed to the first embodiment of the present invention;

5 FIG. 10 is a schematic view for illustrating a first modified example of a laser thermal transferring method that can be employed to the first embodiment of the present invention;

FIG. 11 is a schematic view for illustrating a second modified example of a thermal transferring method that can be employed to the first embodiment of  
10 the present invention;

FIG. 12 is a schematic view for illustrating a third modified example of a laser thermal transferring method that can be employed to the first embodiment of the present invention;

FIG. 13 is a schematic view for illustrating a transferring apparatus for  
15 realizing the first embodiment of the present invention;

FIG. 14 is a block diagram for illustrating a method for fabricating an organic electroluminescent display according to a second embodiment of the present invention; and

FIG. 15 is a graph for illustrating a sectional energy distribution of a  
20 laser beam applied to the second embodiment.

#### **DETAILED DESCRIPTION OF THE PREFERRED EMBODIMENTS**

Preferred embodiments of the present invention will be described in

detail with reference to the accompanying drawings.

FIG. 3 shows an organic electroluminescent display fabricated under the present invention, and FIG. 4 shows a method for fabricating an organic electroluminescent display according to a first embodiment of the present invention.

As shown in the drawings, a first electrode layer 12 having a thickness of about 100-500nm is formed on a transparent substrate 10 by sputtering ITO (Indium Tin Oxide).

An assistant layer (hole transport layer) 14 having a thickness of about 10-100nm is formed on the first electrode layer 12 by, for example, a spin coating process, a dip coating process, a vacuum evaporative deposition process, or a thermal transferring process. An R. G. B organic luminescent layer 16 is formed on the assistant layer (hole transport layer) 14 by a thermal transferring process according to a feature of the present invention. A second electrode layer 18 intersecting the first electrode layer at right angles is formed on the organic luminescent layer 16.

Preferably, the second electrode layer 18 is formed by depositing aluminum through a vacuum evaporative deposition process at a thickness of about 50-1500nm. An insulating layer formed of an organic material such as polymer photoresist or an inorganic material such as SiO<sub>2</sub> and SiN<sub>2</sub> may be deposited between the line patterns of the first electrode.

In addition, a material such as LiF, Ca, or Ba may be disposed between the organic luminescent layer and the second electrode layer.

Preferably, the organic luminescent layer 16 is formed of a poly

phenylene vinylene (PPV)-based material or poly fluorine (PF)-based material.

FIG. 5 shows a schematic view for illustrating a laser thermal transferring method described with reference to FIG. 4.

In the drawing, the reference numeral 22 indicates a laser beam for  
5 scanning a pattern 20.

The laser beam 22 moves from left to right in the drawing (i.e., in an X-direction) along the pattern 20 to perform the scanning process. At this point, while moving in the X-direction, the laser beam 22 dithers in a Y-direction.

By the dithering movement of the laser beam 22, the thermal  
10 transferring process is effectively realized even at both edges 20a and 20b of the pattern 20. The dithering movement is realized by alternating the advancing direction of the laser beam under the control of an acousto-optic modulator (AOM).

In addition, the dithering speed (i.e., a moving speed in the Y-direction)  
15 is preferably higher than the advancing speed (i.e., an advancing speed in the X-direction). That is, considering the advancing speed and the energy distribution, it is preferable to set the dithering speed at about 100-10,000 KHz.

Although the section of the laser beam may be formed in a circular-shape, but it is more preferable to be formed in an oval-shape.  
20 Particularly, as shown in the drawing, the section of the oval-shaped laser beam 22 is designed such that a diameter in a direction of an X-axis (in the advancing direction) is greater than a diameter in a direction of a Y-axis (in the dithering direction). Therefore, when the scanning is performed, the overlap ratio of the laser beams is increased, whereby the energy distribution is uniformly applied

to the entire portion of the pattern 20.

When the lateral width  $W$  of the pattern 20 is 60-150 $\mu\text{m}$ , it is preferable that the section of the laser beam is oval-shaped having the X-axis diameter of 200-500 $\mu\text{m}$  and the Y-axis diameter of 15-50 $\mu\text{m}$ .

5 As shown in FIGS. 6 to 8, the laser beam performs its scanning operation while making a sine-wave (see FIG. 6), a sawtooth-wave (see FIG. 7), a trapezoid-wave (see FIG. 8), or a modified sine-wave (not shown). At this point, the sectional energy distribution of the laser beam 22 is as shown in FIG. 9.

10 As shown in FIG. 9, when the laser beam performs its scanning operating without the dithering movement, the laser beam (i.e., Gaussian beam B1) has an energy distribution having an inclination reduced as it goes from the central portion to the edges of the pattern.

15 However, the laser beam 22 of the present invention has an energy distribution having an inclination steeply increased as it goes from the central portion to the edges of the pattern (See graphs B2 and B3 in FIG. 9 which respectively represent the laser beams performing their dithering movements in the shape of the sine-wave and the trapezoid-wave).

20 As described above, the intensity of the laser beam 22 of the present invention is not reduced even at the edges 20a and 20b of the pattern 20, thereby effectively realizing the thermal transferring process. That is; as in the conventional laser beam B1, when the beam intensity is increased to compensate for the intensity of the beam edge, the surface of the pattern becomes uneven. However, the laser beam of the present invention has the

beam intensity throughout its entire area, there is no need to increase the beam intensity to compensate for the beam edge. As a result, the flatness of the pattern can be improved.

In the above-described first embodiment, a single laser beam is radiated  
5 from a single laser unit. However, the present invention is not limited to this.

That is, as shown in FIG. 10, plural split laser beams 22 and 22' may be radiated from a single laser unit (not shown) so that plural organic luminescent layer patterns 20 and 20' are simultaneously scanned. Preferably, the plural split laser beams are synchronized. This allows the process time to be saved.

10 Alternatively, as shown in FIG. 11, plural laser beams radiated from plural laser units are overlapped one another to form a single overlapped laser beam 32. As more than two laser beams are overlapped, the beam intensity is increased, reducing the scanning time.

Alternatively, as shown in FIG. 12, plural laser beams 42 and 44 are  
15 radiated from plural laser units (not shown) and perform the scanning operation with different phases.

FIG. 13 shows a thermal transferring apparatus for realizing the above-described thermal transferring methods.

A light source 50 radiates a solid laser beam such as ND/YAG or a gas  
20 laser beam such as CO<sub>2</sub> laser.

As described above, the radiated laser beam may be the single laser beam or the split laser beams or the single overlapped laser beam. The split laser beams may be advanced in an overlapped state or in different phases.

The laser beam (i.e., the single laser beam or the split laser beams or

the single overlapped laser beam) radiated from the light source 50 is adjusted in its intensity by a modulator 52 and then reach a scanning mirror 56 via a first lens array 54.

6 The scanning mirror 56 guides the laser beam path to the target on the substrate.

The laser beam reached the scanning mirror 56 is emitted to the donor film 60, on which a luminescent material is deposited, via a second lens array 58. Then, only a portion of the donor film 60, which is scanned by the laser beam, is transferred to the substrate 62.

10 The donor film 60 and the substrate 62 are supported on a stage 64 whose movement is controlled by a computer 66. The computer 66 also controls the scanning mirror 56 through a scanning mirror controller 68.

The dithering movement of the laser beam is controlled by the modulator 52 which is controlled by the computer 66.

15 In the above modified examples, the laser beams are dithered various type. However, the present invention is not limited to this. As shown in FIGS. 14 and 15, plural laser beams having a different energy distribution from each other may be mixed. That is, a complex laser beam B4 may be formed by mixing a laser beam B5 having a smooth inclination at the  $P_e'$  (peak of energy of the laser beam B5)/2 and laser beams B6 and B6' having a steep inclination at the  $P_e''$  (peak of energy of the laser beams B6 AND B6')/2.

20 As the laser beam B5, laser beam having an inclination of about 1.0-6.0%/μm at the  $P_e'/2$  and a lateral diameter of about 40-200μm is preferably used, and as the laser beams B6 and B6', laser having an inclination of about

3-8%/μm at the  $P_e/2$  and a lateral diameter of about 30-75μm is preferably used.

Accordingly, the complex laser beam B4 has an inclination of the energy distribution above 2.0%/μm at the  $P_e/2$ . This shows that the inclination of the complex laser beam is greater than that of the Gaussian beam (B1 in FIG. 1).

The Gaussian beam has an inclination of about 1.4%/μm at the peak of energy/2.

The complex laser beam B4 has a section formed in an oval-shape having a longitudinal diameter greater than a lateral diameter, the longitudinal diameter is formed in a scan direction, and power of about 6W(Watt) and an advancing speed of about 5-11m/sec.

As describe above, the laser beam (i.e., Gaussian beam B1) has an energy distribution having a smooth inclination as it goes from the central portion to the edges of the pattern, while the complex laser beam B4 of the present invention has an energy distribution having a steep inclination as it goes from the central portion to the edges of the pattern. That is, the intensity of the complex laser beam B4 is not reduced even at the edges 20a and 20b of the pattern 20, thereby effectively realizing the thermal transferring process. That is, as in the conventional laser beam B1, when the beam intensity is increased to compensate for the intensity of the beam edge, the surface of the pattern becomes uneven. However, the complex laser beam B4 of the present invention has the beam intensity through out its entire area, there is no need to increase the beam intensity to compensate for the beam edge. As a result, the flatness of the pattern can be improved.

While this invention has been described in connection with what is presently considered to be the most practical and preferred embodiments, it is to be understood that the invention is not limited to the disclosed embodiments, but, on the contrary, is intended to cover various modifications and equivalent arrangements included within the spirit and scope of the appended claims.

专利名称(译)	制造有机电致发光显示器的方法		
公开(公告)号	<a href="#">US6936300</a>	公开(公告)日	2005-08-30
申请号	US09/935332	申请日	2001-08-23
[标]申请(专利权)人(译)	李圣TAEK KWON张赫 KANG TAE MIN PARK JOON YOUNG		
申请(专利权)人(译)	李圣泽 KWON张赫 KANG TAE MIN PARK JOON YOUNG		
当前申请(专利权)人(译)	三星SDI CO. , LTD.		
[标]发明人	LEE SEONG TAEK KWON JANG HYUK KANG TAE MIN PARK JOON YOUNG		
发明人	LEE, SEONG TAEK KWON, JANG HYUK KANG, TAE MIN PARK, JOON YOUNG		
IPC分类号	H01L51/40 H01L51/05 H05B33/10 H01L51/00 B05D5/06 B05D5/12		
CPC分类号	H01L51/0009		
优先权	1020000049287 2000-08-24 KR		
其他公开文献	US20020028626A1		
外部链接	<a href="#">Espacenet</a> <a href="#">USPTO</a>		

摘要(译)

关于制造具有改善的表面平坦度和厚度均匀性以及改善图案边缘区域的图像质量的有机电致发光显示器的方法，制造有机电致发光显示器的方法包括以下步骤：在其上形成第一电极层透明基板，第一电极层为正电极；在第一电极层上形成辅助层；通过使用激光束扫描供体膜在辅助层上形成有机发光层，供体膜设置在具有R、G和B发光材料的基板上；去除供体膜；在有机发光层上形成第二电极层，第二电极层是负电极，其中形成有机发光层的步骤包括在垂直于激光束扫描方向的方向上抖动激光束的步骤。

